



## Option "T" Shower Screens Installation Instructions

Please read all steps clearly before installation.

### step 1

Take out adjusting screws from inside of compensator (screen side only). Place compensator against wall and mark off hole position when plumb. Then drill into wall with a No.10 masonry drill bit. Fit red plugs and fix compensator with No.8 x 1 1/2" pan head screw.

See Fig. 1

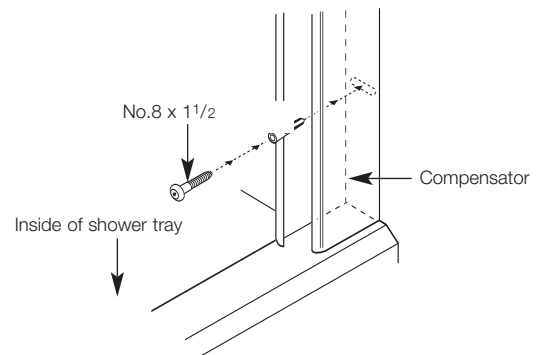

Fig. 1

### step 2

Slide screens into outer compensator, re-attach adjusting plate and clamping plate.

When screens are aligned and bottom seal is in continuous contact with shower tray, mark off hole positions on to shower tray, drill a 3.0mm hole and fasten into tray with a No.6 x 1" pan head screw.

See Fig. 2

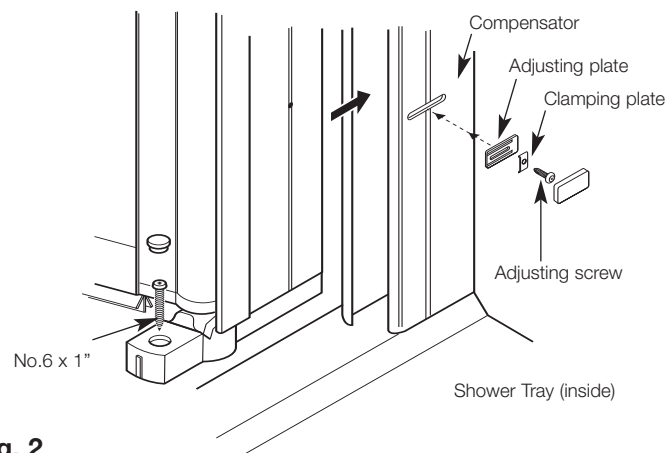

Fig. 2

## step 3

When screens are both inline and the bottom seal is in continuous contact with the shower tray, mark off hole positions for the post and bottom pivot.

See Figs. 3 & 4

### Option T

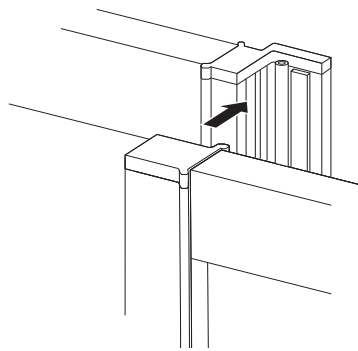

**Fig. 3**  
INLINE SCREENS CLOSING TOGETHER

Please note different hole sizes for post block and bottom pivot.

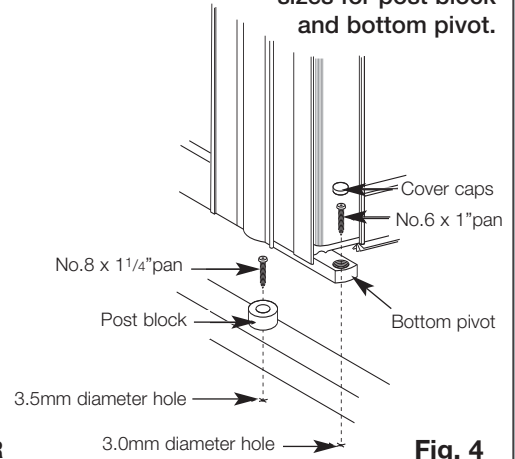
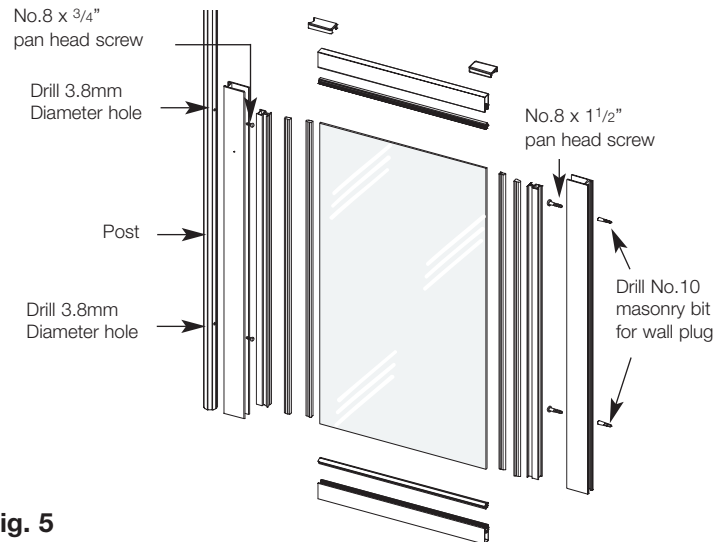

**Fig. 4**

## step 4

Disassemble the panel by removing the outer compensators. The compensators must be drilled and screwed to the post and wall respectively (refer to diagram for the correct screw size) with locking screw holes at the top of the compensator's, facing inside the shower tray.

See Fig. 5



**Fig. 5**

## step 5

Measure between the back of the compensators at the top and bottom points to allow for walls being out of plumb, then deduct 15mm before cutting styrene, top and bottom and U channel gaskets with a fine tooth blade this allows for easy installation.

See Fig. 6

**Fig. 6**

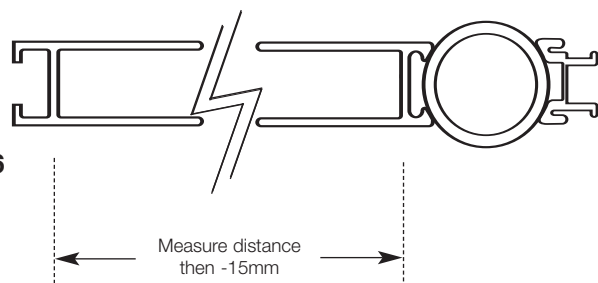

CUTTING OF STYRENE/ ALUMINIUM/ RUBBER MAY BE DONE SEPARATELY.  
TO RE-ASSEMBLE THESE ITEMS:  
PUSH U CHANNEL BACK ON TO STYRENE.  
PUSH THE TOP/ BOTTOM RAIL BACK ON TO RUBBER.

## step 6

Once cut, and re-assembled, re-attach spacers down both sides of the panel and slide down between legs of compensators. The top rail should be level with the top of the compensators. With both locking holes facing into the showering area, drill through hole with a 3.5mm bit, using No.8 x 1/2" pan head screw and fully tighten.

See Fig. 7

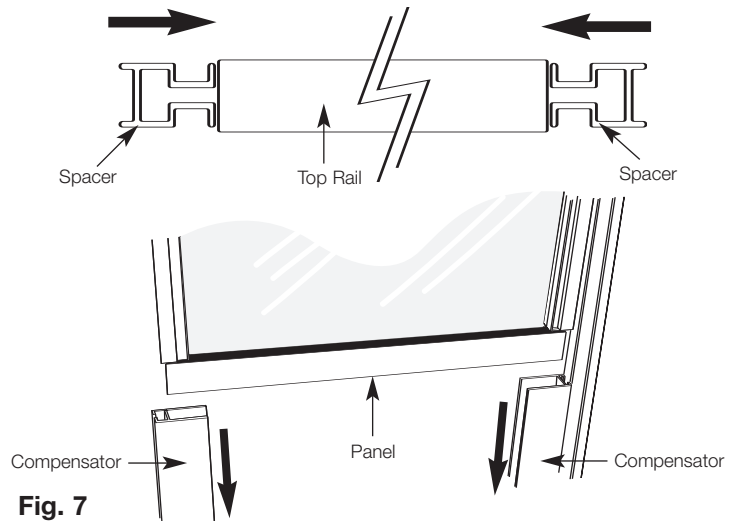

Fig. 7

## step 7

Re-glaze panel using 4 x rubber gasket supplied. Push gasket back into panel evenly on both sides making sure the gasket finishes with outer edge of compensators

See Fig.8

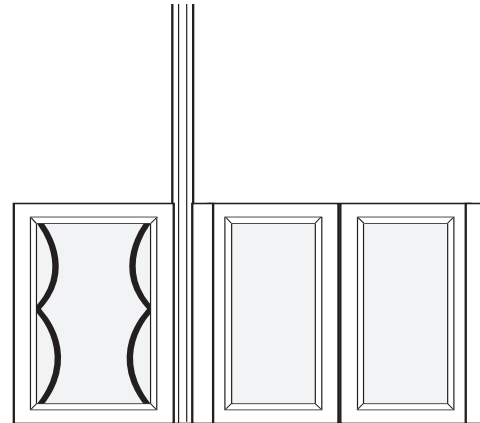

Fig. 8

**NOTE: IF CURTAIN RAIL KIT IS SUPPLIED THEN PLEASE BE AWARE THAT CURTAIN RAILS COME OVERSIZED AND WILL NEED TO BE CUT TO SIZE. PLEASE FIT CORRECT AMOUNT OF HOOKS AND GLIDERS TO RAIL BEFORE INSTALLATION.**

## step 8

Curtain rails are to be positioned on the inside of screens. See Fig.9

When rail is level, mark off curtain rail bracket hole positions, then drill into wall with a No.10 masonry drill bit, then fit with a No. 8 x 1 1/2" and cover caps. See Fig. 10

**Note: For installation on Mullen shower trays, please position screens on top of flat strip between clamping bar and shower floor area.**

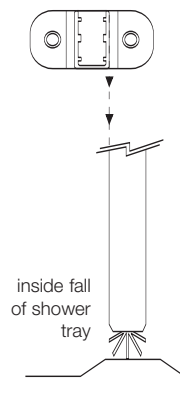

Fig. 9

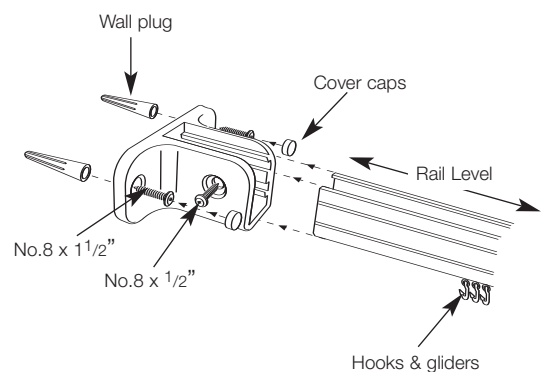
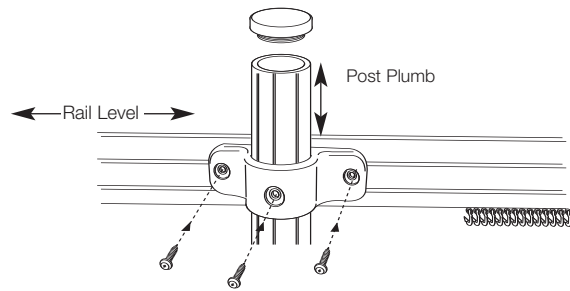

Fig. 10

## step 9

When rail is level and post is plumb using bracket supplied, drill into post and rail using a 3.5mm drill bit and fasten with No.8 x 1/2" pan head screw and finish off with cover caps.

**See Fig.11**



**Fig. 11**